

*Harrier*

*48*

---

CODE 485T

(Blade Brake Clutch - Auto Drive)

## **OWNER'S HANDBOOK**

## CERTIFICATE OF CONFORMITY

I, the undersigned M.A. Wright, of:

HAYTER LIMITED, Spellbrook, Bishop's Stortford  
Herts CM23 4BU  
ENGLAND

certify that the lawnmowers:

1. Machine Type No.	CODE 485T
2. Category.	Combustion Engine
3. Make.	Hayter
4. Type.	Rotary
5. Engine - Manufacturer.	Briggs & Stratton
- Type.	12G882-1512-21
- Speed of rotation during test.	2950 rpm

Conforms to the specifications of Directive 84/538/EEC as adapted to technical progress by Directive 87/252/EEC and amended by Directive 88/180/EEC.

Guaranteed maximum sound power level. 96 dB(A)

- Type of cutting device	Cutterbar
- Width of cutting device	48 cm
- Speed of rotation of the cutting device	2950 rpm

TESTED AT SUDBURY, SUFFOLK, ENGLAND 25.03.98

Signed



M.A. Wright  
(Technical Director)

## EC DECLARATION OF CONFORMITY

Company Name HAYTER LIMITED

Company Address Spellbrook  
Bishop's Stortford  
Herts. CM23 4BU  
ENGLAND

Machine Type No., CODE 485T  
Models Harrier 48 BBC



Directives complied with:  
93/68/EEC Essential. Health & Safety Requirements Relating to the Design & Construction of Machinery and Safety Components.

84/538/EEC amended by 87/252/EEC and 88/180/EEC Permissible Sound Power Levels of Lawn Mowers  
89/336/EEC amended by 92/31/EEC Electromagnetic Compatibility

Standards Used: EN292, EN836, ENISO14982

I declare on behalf of Hayter Limited that these machines conform to the EC Essential Health & Safety Requirements.

Signed



Date:21.09.99

M.A. Wright  
(Technical Director)

## VIBRATION INFORMATION

Lawnmower vibration information. RMS acceleration measured in 3 - axes at operators contact position on the handlebars. **CODE 485T = 6 ms<sup>-2</sup>**

CONTENTS	Page No.
<b>INTRODUCTION</b>	<b>1.3</b>
<b>WARRANTY</b>	<b>1.4</b>
<b>SAFETY PRECAUTIONS</b>	<b>1.5 - 1.9</b>
Decals	1.9
<b>SPECIFICATIONS</b>	<b>1.10</b>
<b>ASSEMBLY INSTRUCTIONS</b>	<b>1.11 - 1.13</b>
General Assembly	1.11
Assembling the Mower for the First Time	1.12- 1.13
<b>STARTING THE ENGINE</b>	<b>1.14 - 1.16</b>
Before Starting the Engine	1.14 - 1.15
To Start the Engine	1.16
<b>STOPPING THE ENGINE</b>	<b>1.17</b>
<b>OPERATING THE MOWER</b>	<b>1.18 - 1.23</b>
Safety Notice	1.18
Height of Cut	1.18
Travel	1.19
Turning the Mower	1.19
Mowing with Grass Collection	1.20
Mowing without Grass Collection	1.21
Heavy Growth	1.21
Moving the Mower across Non-Grassed Areas	1.21
Cutterbar Operation	1.22
Mowing and Grass Care Tips	1.23 - 1.24
<b>MAINTENANCE</b>	<b>1.25 - 1.33</b>
Engine	1.25
Throttle Cable Adjustment	1.25
Carburettor Adjustments	1.26
Oil Service	1.26
Air Cleaner Service	1.27
Spark Plug Service	1.27
Keeping the Engine Clean	1.28
Grassbag	1.28
Deck Housing	1.28

**CONTENTS****Page No.****MAINTENANCE Continued.**

Securing Nuts and Bolts	1.29
Lubrication	1.29
Clutch Cable Adjustment	1.29
Cutterbar	1.30 - 1.31
Maintenance Schedule	1.32 - 1.33
- After First 5 Hours	1.32
- Every 5 Hours or Daily	1.32
- Every 25 Hours or Every Season	1.32
- Every 50 Hours or Every Season	1.33
- Every 100 Hours or Every Season	1.33

**PREPARING THE MOWER FOR STORAGE 1.34****FAULT FINDING 1.35 - 1.37****485T PARTS LIST 2.1 - 2.3****485T PARTS DIAGRAM 2.4****ENGINE ANCILLARY PARTS 2.5****WARRANTY ENGINE 2.6****NOTES 2.7****CUSTOMER INFORMATION 2.8**

**INTRODUCTION**

Thank you for purchasing a **Hayter** mower. The following pages are designed to help you gain safe and efficient service from your machine.

**IMPORTANT:** This 'Owners Handbook' should be regarded as part of the machine as it gives essential information regarding machine safety, operation, maintenance and specifications. Read and understand this handbook prior to operating your machine for the first time. Make sure you are familiar with all the controls and points of regular maintenance. If you have any doubts, consult your **Hayter** authorised dealer who will be pleased to give you assistance.

**IMPORTANT:** This machine is designed solely for use in a domestic grass cutting environment. Use in any other way is considered as contrary to the intended use. Compliance with and strict adherence to the conditions of operation, service and repair as specified in this handbook also constitute essential elements of the intended use.

This machine should be operated, serviced and repaired only by persons who are familiar with its particular characteristics and who are acquainted with the relevant safety procedures.

The safety precautions listed here in and all other generally recognised regulations on safety must be observed at all times.

Any arbitrary modifications carried out to this machine may relieve Hayter Limited of liability for any resulting damage or injury.

All **Hayter** mowers are robustly constructed and designed for efficient economical performance under normal mowing conditions. Correct operation and maintenance will ensure a long and satisfactory service life. Prior to despatch from our factory every effort is made to ensure your machine arrives in perfect condition. Your dealer will carry out a pre-delivery inspection to ensure that there has been no transit damage prior to installation.

**Please allow your dealer to familiarise you with the controls and safety features of the machine during installation.**

Throughout this handbook all references to left hand and right hand are as viewed from behind the handlebar, facing in the direction of forward travel.

This handbook is based on information available at the time of publication.

**HAYTER LIMITED** reserve the right to make changes at any time without notice.



**LIMITED WARRANTY**

**Hayter Limited** warrants to the original user/purchaser that this unit shall be free from defects in material and workmanship under normal use and service for a period of **three years** from the date of purchase. The manufacturers of the engine and battery pack system (where applicable) furnish their own warranty and services are provided through their authorised network (Refer to "Engine/Battery Pack Warranty Statement"). To qualify for the full benefit of the warranty, the warranty registration card must be returned within 60 days of purchase. Subject to the conditions and exclusions noted in this limited warranty, we shall at our option, repair or replace any warranted part during the applicable period. If you are in doubt or experience any difficulty, please consult a Hayter Authorised Service Dealer for clarification.

To qualify for the extended warranty (second and third year) of the three year limited warranty the machine must have annual services carried out by an Authorised Hayter Service Dealer. These chargeable services should be carried out within 12 and 24 months of the date of purchase.

Excluded from the extended warranty period are those items which are subject to normal wear and tear e.g. tyres, wheels, cutterbars, cables, batteries and other consumable wearing parts.

All consumer machines which are fitted with a **genuine** Hayter friction disc as original equipment before use, are covered by a **Lifetime Warranty** against the engine crankshaft bending. **Note:** friction washers, blade brake units and other such devices are not applicable. Only machines fitted with a **genuine** Hayter friction disc, which are used in accordance with the recommended operating and maintenance procedures, are covered.

This warranty does not apply to any unit that has been tampered with, altered, misused, abused or used for hire, and will become invalid if non genuine Hayter parts are fitted. This warranty does not cover minor mechanical adjustments unless they are due to defective material or workmanship. Consult the Owner's Handbook or a Hayter Authorised Service Dealer for assistance when making these adjustments.

**A warranty period of 90 days applies to machines used for commercial purposes.**

To make a warranty claim, return the unit to a Hayter authorised dealer along with proof of purchase stating the machine serial number and date of purchase. The service receipt(s) or this Owners Handbook with the 1st/2nd year service boxes fully completed, must be produced as proof of entitlement to the extended warranty period. Subject to the conditions and exclusions in this limited warranty, the authorised dealer will, at our option, repair or replace any warranted part within the duration of the warranty period.

This limited warranty gives you specific legal rights and is in addition to any statutory rights to which you may be entitled and your statutory rights are not affected by this warranty. If you need additional information concerning this written warranty, or assistance in obtaining services, please write to : **HAYTER LIMITED, Service Department, Spellbrook, Bishop's Stortford, Hertfordshire CM23 4BU**

**UK ONLY:** Details of your local **Hayter** authorised dealer are contained in Yellow Pages or contact:- Freephone 0800 616298.

1st Year  
Service  
Record

DEALER STAMP

2nd Year  
Service  
Record

DEALER STAMP

Date.....

Date.....

Signed.....

Signed.....

**SAFETY PRECAUTIONS**

**THIS SYMBOL MEANS BE ALERT! YOUR SAFETY IS INVOLVED. WHEN YOU SEE THIS SYMBOL BE ALERT TO THE POSSIBILITY OF INJURY. CAREFULLY READ THE MESSAGE THAT FOLLOWS AND INFORM OTHERS.**

**EXERCISE GREAT CARE AND FOLLOW THE ADVICE GIVEN TO AVOID POTENTIALLY HAZARDOUS SITUATIONS.**

**The Harrier 48 is perfectly safe if used correctly. Failure to observe the following simple precautions may result in serious injury.**

**Training:**

Read the instructions carefully. Ensure that you are familiar with the controls and the proper use of the equipment. Learn how to stop the mower quickly in an emergency.



Never allow children or people unfamiliar with these instructions to use the mower.



Never mow while people, especially children, or pets are nearby.



Keep in mind that the user is responsible for accidents or hazards occurring to other people or their property.

**Preparation:**

While mowing, always wear substantial footwear and long trousers. Do not operate the equipment when barefoot or wearing sandals.



Thoroughly inspect the area where the mower is to be used and remove all objects which may be thrown by the machine.



**WARNING:** Petrol is highly flammable.

- Store fuel in containers specifically designed for this purpose.

- Refuel outdoors only and do not smoke while refuelling.

- Add fuel before starting the engine. Never remove the cap from the fuel tank or add petrol while the engine is running or when the engine is hot. Allow the engine to cool for at least 2 minutes before refuelling.

- Do not attempt to start the engine if petrol is spilled or a smell of petrol is present. Move the mower away from the area of spillage and avoid creating any source of ignition until petrol vapours have dissipated.

- Always use fresh fuel. Stale fuel can block the carburettor and cause leakage.

**SAFETY PRECAUTIONS****Continued.**

- Replace fuel tank and container caps securely.
- Replace faulty exhaust mufflers.

 Always ensure that the mower is in a safe operating condition. Frequently check all nuts, bolts and screws for tightness. Use only genuine **Hayter** replacement parts.

 A damaged cutterbar or loose fixing screws are major hazards. Before use, visually inspect the cutting mechanism to ensure that it is in good condition. A damaged cutterbar must be replaced immediately with a genuine **Hayter** replacement part. A cutterbar which is slightly worn can be re-sharpened. Ensure that both cutting edges are re-sharpened equally to maintain balance. An unbalanced cutterbar may cause serious damage to your machine. Refer to “Maintenance”.

**Operation:**

 Do not operate the engine in a confined space where dangerous carbon monoxide fumes can collect.

 Always pull the starter cord slowly until resistance is felt. Then pull the cord rapidly to avoid kickback and prevent hand or arm injury.

 Mow only in daylight or good artificial light.

 Avoid using the mower on wet grass, where feasible.

 Always be sure of your footing on slopes.

 Walk, never run.

 Mow across the face of slopes, never up and down.

 Exercise extreme caution when changing direction on slopes.

 Do not mow excessively steep slopes.

 Use extreme caution when reversing or pulling the mower towards you.











 Stop the engine if the mower has to be tilted for transportation when crossing surfaces other than grass and when transporting the mower to and from the area to be mowed.

 Never operate the mower unless the guards are securely in position and in good condition.



**SAFETY PRECAUTIONS**

Continued.

-  Do not change the engine governor settings or overspeed the engine.
-  Disengage the rear roller drive clutch before starting the engine.
-  Start the engine carefully, with feet well away from the cutterbar.
-  Do not tilt the mower when starting the engine.
-  Do not put hands or feet near or under rotating parts.
-  Never pick up or carry a mower while the engine is running.
-  Stop the engine and disconnect the spark plug lead:
  - Before clearing blockages or unclogging the discharge chute.
  - Before cleaning / checking or working on the mower.
  - After striking a foreign object. Inspect the mower for damage and make repairs before restarting and operating the mower.
  - If the mower starts to vibrate abnormally (check immediately).
-  Stop the engine:
  - Whenever you leave the mower.
  - Before refuelling.
-  Never lift the deflector plate whilst the mower is in operation.
-  Never touch the engine muffler / muffler guard or cooling fins when the engine is hot.















**WARNING: THE CUTTERBAR CAN CONTINUE TO ROTATE  
AFTER THE ENGINE IS SWITCHED OFF**

**SAFETY PRECAUTIONS**

Continued.

**Maintenance and Storage:**

-  Keep all nuts, bolts and screws tight to ensure that the equipment is in safe operating condition.
-  Frequently check fuel lines and fittings for cracks or leaks and replace if necessary.
-  Never check for a spark with the spark plug removed. (Use an approved tester).
-  Never crank the engine with the spark plug removed. If the engine is flooded, move the throttle to the 'fast' position and crank the engine until it starts.
-  Never strike the flywheel with a hammer or hard object as this may cause the flywheel to shatter in operation. Always use the correct tools to service the engine.
-  Never operate the engine without a muffler guard. Inspect the muffler periodically and replace if worn or leaking.
-  Never start the engine with the air-cleaner or air-cleaner cover removed.
-  Never store the mower with petrol in the tank within an enclosed area where fumes may reach an open flame or spark.
-  Allow the engine to cool before storing in any enclosure.
-  To reduce the fire hazard, keep the engine, muffler, cooling fins and petrol storage area free of grass, leaves, or excessive grease.
-  Check the grassbag frequently for wear or deterioration.
-  Replace worn or damaged parts for safety.
-  If the fuel tank has to be drained, it is essential that this be done outdoors.

**DECALS**

**WARNING DECAL**

**WARNING - RISK OF DANGER - SAFETY ALERT.**

**DANGER OF SEVERING TOES OR FINGERS IN CUTTING MECHANISM.**

**DANGER OF BEING HIT BY THROWN OBJECTS. KEEP BYSTANDERS AT A SAFE DISTANCE FROM THE MACHINE.**

**STOP ENGINE AND REMOVE SPARK PLUG LEAD BEFORE PERFORMING MAINTENANCE OR REPAIR WORK.**

**CAREFULLY READ THE OWNERS HANDBOOK BEFORE USING THE MACHINE.**

**CUT HEIGHT ADJUSTMENT:**



**THROTTLE CONTROL:**



**BLADE BRAKE CLUTCH DECAL:**

Part No. 343019



## SPECIFICATIONS

<b>MODELS</b>	<b>CODE 485T</b> Blade Brake Clutch - Auto Drive
<b>Engine</b>	Briggs & Stratton Diamond XTL-45
<b>Engine Type</b>	12G882-1512-21
<b>Engine / Cutterbar Speed</b>	2950 rpm
<b>Fuel Type</b>	Unleaded Petrol
<b>Fuel Capacity</b>	1.5 litres
<b>Oil Type</b>	SAE 30 engine oil
<b>Oil Sump Capacity</b>	0.6 litres
<b>Cutting Width</b>	480mm
<b>Cutting Height</b>	12 - 65mm
<b>Overall Dimensions</b>	1040 x 514 x 1377mm
<b>Dry Weight</b>	49 Kg

## ASSEMBLY INSTRUCTIONS

## SAFETY NOTICE



Before using the mower, read the owner's handbook carefully.  
Pay particular attention to the safety precautions.



## GENERAL ASSEMBLY

1. Spark Plug Lead
2. Air Cleaner
3. Engine Cover
4. Fuel Cap
5. Serial Number Label
6. Oil Filler & Dipstick
7. Rear Deflector
8. Engine Start Grip
9. Throttle Control
10. Cutterbar Stop Lever
11. Handlebar
12. Ground Drive Clutch Lever
13. Blade Brake Clutch Lever
14. Grassbag Assembly
15. Handlebar Securing Knob
16. Handlebar Height Adjust Knob
17. Height of Cut Lever
18. Muffler Guard

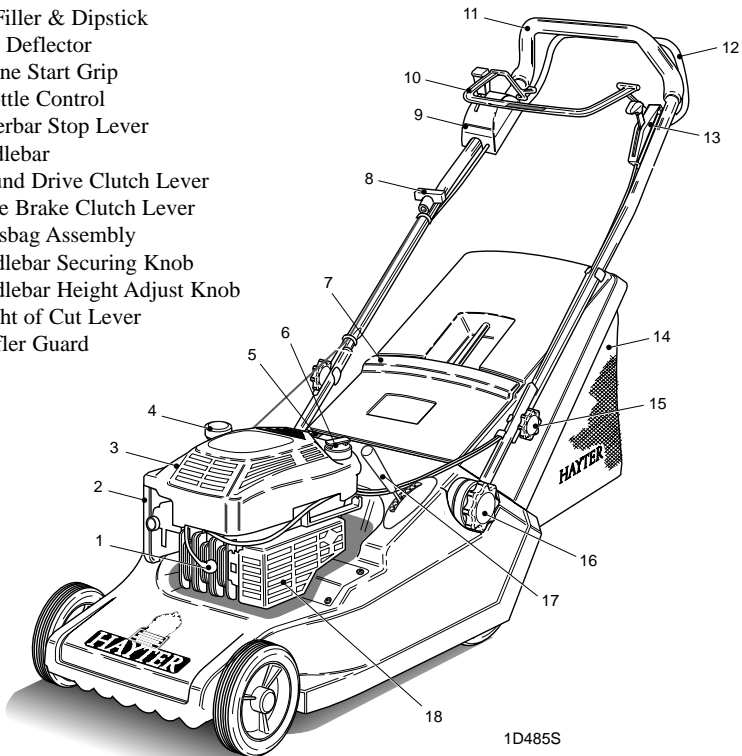

1D485S

### ASSEMBLING THE MOWER FOR THE FIRST TIME

**Check that parts are delivered correctly:** Remove the mower from the packaging and check that all loose items have been supplied correctly. Refer to the delivery checklist opposite and the general assembly. If any items are missing contact, your local Hayter dealer.

#### DELIVERY CHECKLIST

Description	Quantity
Grassbag	1
Owner's Handbook	1
Warranty Registration Card	1

**Assemble the handlebar:** Unscrew the handlebar securing knobs sufficiently to allow the handlebar to be pivoted. Move the engine stop lever away from the engine to avoid damage and unfold the handlebar to its operating position. Ensure that both Knobs are on the outside of the handlebar and the cable guide is positioned as shown. Tighten to secure handlebar in position.

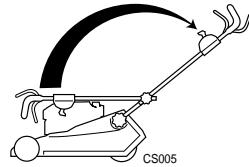

**IMPORTANT - PREVENT DAMAGE :** When unfolding the handlebar, take care to ensure that the controls and cables do not become damaged. Always replace damaged controls and cables before using the mower.

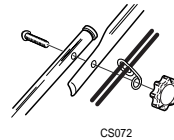

**Adjust height of handlebar:** Unscrew the two larger Knobs at base of handlebar sufficiently to allow it to be moved to the upper, middle or lower position. Secure in best position for comfort. Ensure that both sides are set to the same height.

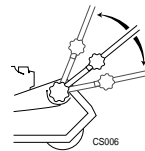

**Assemble the grassbag:** Remove the long ribbon label by cutting it off close to the grassbag. Discard the ribbon label.



**WARNING - AVOID ENTANGLEMENT :** Completely remove this ribbon before using the mower

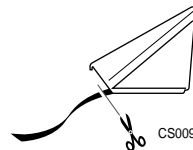

**Grassbag attachment:** Raise the rear deflector. Lower the grassbag through the handlebar and hook in position behind the deflector springs. Lower the grassbag to rest against the rear of the mower. Finally, lower the rear deflector to rest against the top of the grassbag.

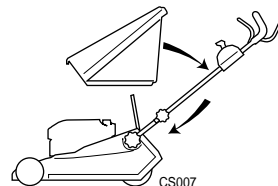

**ASSEMBLING THE MOWER FOR THE FIRST TIME**
**Continued.**

**Check blade brake / clutch controls:** Operate the blade stop lever (A) several times, to ensure the lever moves freely. Hold the lever against the handlebar in position (1) and check that it returns to position (2) when released.

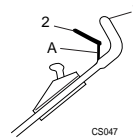

Use the right hand to hold the blade stop lever against the handlebar (1) and use the left hand to push the blade clutch lever (B) to the 'engaged' position (3). Remove the left hand and the blade clutch lever should return to position (4), leaving the blade drive clutch engaged.

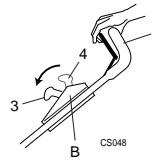

Remove the right hand and check that the blade stop lever automatically returns to position (2). There should be an audible 'clunk' to indicate that the blade drive clutch has disengaged.

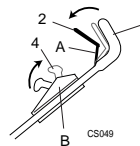

**Check throttle lever operation:** Operate the throttle lever several times and ensure that the cable moves freely whilst operating the engine throttle mechanism. Slight resistance should be felt when the lever moves to the 'choke' position.

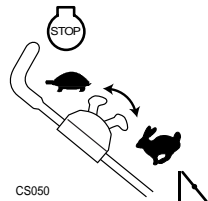

**Check ground drive clutch lever operation:** Operate the clutch lever several times and ensure that the cable moves freely.

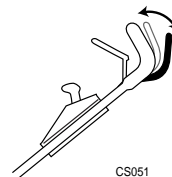

**BEFORE STARTING THE ENGINE**

**IMPORTANT - PREVENT ENGINE DAMAGE:** The engine is shipped without oil or petrol. The engine must be filled with the correct grade of oil and petrol before starting the engine.

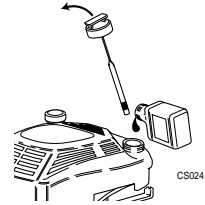

**Oil recommendations:** Always use high quality detergent oil classified "For service SE, SF, SG" SAE 30 oil. Never use additives with recommended oils.

SAE 10W-30 multigrade oil may be used, but this will result in higher engine operating temperatures with consequential high oil consumption. It is imperative that the oil level is checked more frequently if this grade of oil is used in order to guard against serious engine damage.

**Check oil level:** Clean around the oil filler cap before removing. With the mower on a level surface, unscrew and remove the oil filler - dipstick. Wipe oil from it with a clean cloth. Screw the oil filler - dipstick back in place, then unscrew and remove it to check the oil level.

The oil level is correct when it is at the **full** mark on the dipstick. **DO NOT OVERFILL.**

Slowly fill with engine oil as necessary and replace the oil filler - dipstick.

**IMPORTANT:** The oil filler dipstick must be secured to prevent oil leakage during operation.

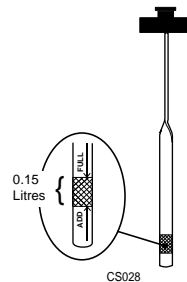



**BEFORE STARTING THE ENGINE**

Continued.

**Fuel Recommendations:** Always use clean, fresh unleaded petrol. Purchase fuel in quantities which can be used within 30 days. Never mix oil with petrol. For added engine protection Briggs & Stratton recommend the use of their fuel additive which is available from an authorised Briggs & Stratton service dealer.

**Check fuel level:** Clean around the fuel filler cap before removing and fill the fuel tank with clean unleaded petrol.

Do not overfill the fuel tank. Allow 6mm minimum of tank space for fuel expansion.

**IMPORTANT: The fuel filler cap must be secured to prevent fuel leakage during operation.**

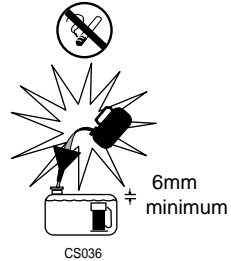

**WARNING - PREVENT ACCIDENTS: The cutterbar rotates when the engine is operating.**

**ALWAYS** operate the engine stop lever several times and ensure the engine stop cable moves freely before starting the engine.

**ALWAYS** position the mower on a level stone free grass surface before starting the engine. Ensure that the cutterbar is set above grass height before the cutterbar drive is engaged to prevent the engine being subjected to excessive load.

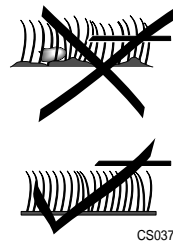

**TO START THE ENGINE**

**Operate the throttle control lever:** Push the lever to 'choke' position before starting a cold engine. It should only be necessary to push the lever to the 'fast' position before starting a warm engine.

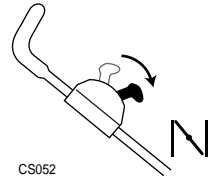

**Operate the engine start - grip:** Stand behind the mower and maintain a firm hold on the handlebar to prevent the mower moving towards you. Use your right hand to hold the engine start - grip and pull slowly until resistance is felt, then pull rapidly to crank the engine. When the engine starts carefully return the engine start - grip to the storage position. If the engine does not start after 5 attempts - refer to "Fault Finding".

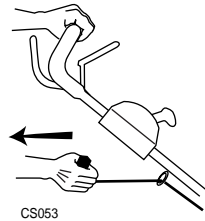

Allow the engine to warm up and return the throttle lever to the 'fast' position after starting a cold engine.

**IMPORTANT - PREVENT ENGINE DAMAGE: Never pull the engine start - grip when the engine is running.**

## STOPPING THE ENGINE

**Stopping the engine:** Push the lever to the rearmost position.

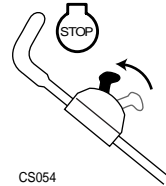

**Emergency stop:** If the engine stop lever fails, move the throttle lever to the 'slow' position and disconnect the spark plug lead to stop the engine.

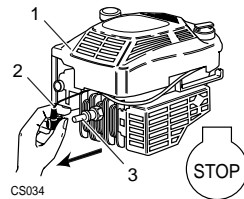

1. Engine
2. Spark Plug Lead
3. Spark plug

## SAFETY NOTICE



**WARNING - PREVENT ACCIDENTAL STARTING :**  
Always stop the engine and disconnect the spark plug lead before cleaning, inspecting or working on the machine.

1. Engine
2. Spark Plug Lead
3. Spark plug

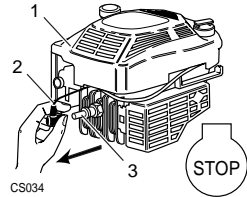

## SAFETY NOTICE



**WARNING - PREVENT ACCIDENTS:** Before mowing, thoroughly inspect the area where the mower is to be used and remove all objects which when contacted by the mower cutterbar could become dangerous projectiles.

Inspect the area for hidden obstructions which when contacted by the cutterbar could risk health and safety. Remember the location of these obstructions and ensure that you mow around them.



**IMPORTANT - PREVENT ENGINE DAMAGE :** DO NOT use the mower on a slope greater than 20 degrees.

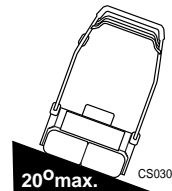

## HEIGHT OF CUT

**To adjust the height of cut:** Grip the lever and pull sideways to disengage it from the locking notch, then push forwards to lower or pull backwards to raise the height of cut. Finally release the lever at the required position and ensure it locks firmly into one of the seven notch settings.

Always select a height of cut to suit operating conditions. Aim to prevent engine overloading and blockages by avoiding low cuts in long grass conditions. Be prepared to make two cuts when the grass is long.

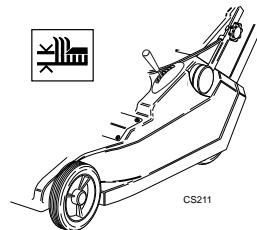

**TRAVEL**

**Forward travel:** Hold the handlebar and operate the clutch lever to power the mower in a forward direction.

Travel speed is controlled by engine speed. Use the throttle control to increase forward travel speed.

Release the clutch lever to stop the mower from travelling in a forward direction.

When the clutch lever is disengaged the mower can be operated as a push model. This feature is useful when mowing in confined areas.

**Reverse travel:** Release the clutch lever. Hold and pull against the handlebar with both hands to reverse the mower towards you.

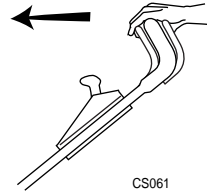

CS061

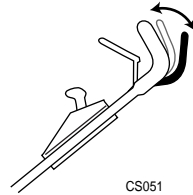

CS051



**WARNING - PREVENT ACCIDENTS:** Always reverse the mower carefully towards you. Always disengage the cutterbar drive before walking backwards with the mower.

**TURNING THE MOWER**

**To make a wide turn:** Steer the mower with the handlebar in the direction required.

**To make a tight turn:** Stop and apply downward pressure on the handlebar to raise the front wheels of the mower just above ground level and steer the mower using the handlebar in the required direction.



**WARNING - PREVENT ACCIDENTS:** DO NOT raise the front of the mower excessively when making a turn. NEVER raise the rear of the mower when the engine is running.

### MOWING WITH GRASS COLLECTION

The grassbag is designed to collect grass clippings. For optimum performance, mow in dry conditions with the throttle control set at 'fast'.



**WARNING - PREVENT ACCIDENTS: ALWAYS check the condition of the grassbag for signs of damage and ensure the rear deflector is positioned correctly on top of the grassbag. Replace a damaged grassbag immediately. DO NOT operate the mower with a damaged grassbag. ALWAYS stop the engine and disconnect the spark plug lead before attempting to remove a grass blockage. Ensure the rear grass deflector is sitting on the grassbag correctly.**

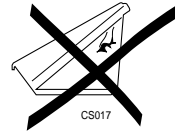

**Grassbag attachment:** Raise the rear deflector. Lower the grassbag through the handlebar and hook in position behind the deflector springs. Lower the grassbag to rest against the rear of the mower. Finally, lower the rear deflector to rest against the top of the grassbag.

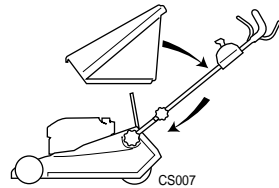

**Grassbag removal:** Raise the rear deflector and lift the grassbag through the handlebar. Finally lower the rear deflector to rest against the rear of the mower.

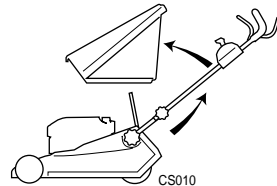

**Grassbag emptying:** To empty the grassbag, pour out the grass clippings and shake the grassbag vigorously to clean the airways. Good grass collection depends on good air flow through the grassbag. When collecting grass clippings it is important that the grassbag is emptied regularly to prevent blockages and engine overloading.

**MOWING WITHOUT GRASS COLLECTION**

To mow without collecting the grass clippings, remove the grassbag and operate the mower with the rear deflector in its lowest position.

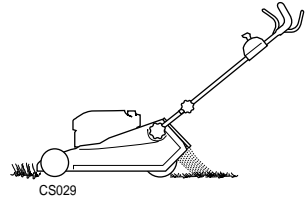

**WARNING - PREVENT ACCIDENTS: ALWAYS check the condition of the rear deflector for signs of damage and ensure it is positioned correctly on the rear of the mainframe. Replace a damaged rear deflector immediately. never operate the mower with a damaged rear deflector.**

**HEAVY GROWTH**

Areas of heavy growth should be mown without grass collection. If grass collection is required, first mow the area without grass collection at the maximum height of cut setting. Allow the grass clippings to dry out and then mow the area at the maximum height of cut setting with the grassbag fitted. Reduce the height of cut and mow the area again as necessary until the required finish is obtained.

**MOVING THE MOWER ACROSS NON-GRASSED AREAS**

Set the mower to its maximum height of cut to protect the cutting mechanism when moving the mower over surfaces other than grass.



**WARNING - PREVENT ACCIDENTS : ALWAYS disengage the cutterbar drive and push the mower carefully at slow walking speed when moving the mower over non-grassed areas.**

## CUTTERBAR OPERATION

**General information:** The cutterbar is driven by the engine via a brake/clutch device (1) which enables the cutterbar to be engaged/disengaged using control levers whilst the engine is running. The cutterbar will stop within three seconds of releasing the blade stop lever.

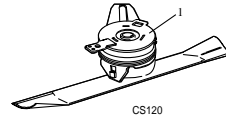

**WARNING - PREVENT ACCIDENTS: DO NOT operate the mower if the cutterbar fails to stop within three seconds. Return the mower to your Hayter dealer for examination and repair.**

A friction device in the blade brake/clutch helps prevent damage occurring to the cutting mechanism when a hidden obstruction or overload is encountered. When the obstruction or overload is removed, the friction device will automatically reset.

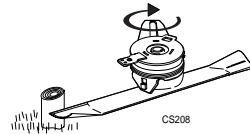

**WARNING - PREVENT ACCIDENTS: ALWAYS disengage the cutterbar drive and stop the engine when a hidden obstruction or excessive vibration is encountered. Disconnect the spark plug lead and examine the cutting mechanism. ALWAYS replace a damaged cutterbar - refer to "Maintenance".**

**Engaging cutterbar drive:** Use the right hand to hold the blade stop lever against the handlebar (1) and use the left hand to push the clutch lever (2) to the 'engaged' position (3). Remove the left hand and the blade clutch lever should return to position (4).

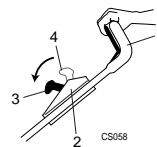

**Disengage cutterbar drive:** Release the blade stop lever to disengage cutterbar drive. Check that the blade stop lever automatically returns to position (2).

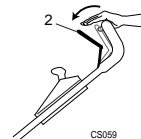

**Emergency stop:** If the cutterbar drive mechanism fails, stop the engine.

**WARNING - PREVENT ACCIDENTS: Do not operate the mower with a faulty cutterbar drive mechanism.**



**MOWING AND GRASS CARE TIPS**

In dry weather conditions leave the grass long to help retain ground moisture.

Aerate the lawn to stimulate soil organisms and root growth. In spring and late summer remove dead grass and aerate the lawn by raking or similar means.

Keep the cutterbar sharp. A blunt cutterbar will tear the grass and cause the tips to turn brown.

Prevent scalping. Plan your direction of travel to mow across hollows and humps.

Prevent grass damage. Take care when turning the mower.

Prevent grass damage. **DO NOT** mow in wet conditions.

Brush the lawn surface to disperse worm casts before mowing.

Spike compacted lawn areas with a fork. Fill the holes with sand to improve aeration and drainage.

Mow lawns in a different direction to the previous cut.

As a general rule the grass clippings should be removed each time you mow. If weather conditions are dry and hot and the grass is weed free, leave the clippings on the lawn to help maintain ground moisture.

Mow lawns twice a week when the grass is growing vigorously in the summer.

Mow lawns once a week in spring, autumn and during prolonged dry weather in the summer.

**Prevent grass damage - DO NOT remove more than one third of the grass height in one cut.**

**MOWING AND GRASS CARE TIPS**

Continued.

**Recommended grass heights for lawns :**

**DANGER** Coarse grasses dominate fine grasses.

General lawn in spring, autumn or prolonged dry period.

General lawn in summer.

Luxury lawn in spring, autumn or prolonged dry period.

Luxury lawn in summer.

**DANGER** Grass strength is reduced.

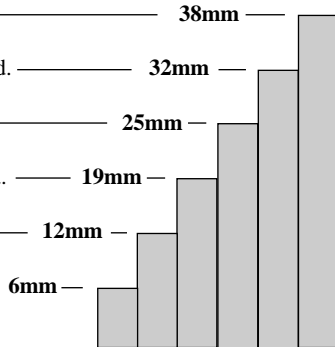

## MAINTENANCE



**WARNING - PREVENT ACCIDENTS:** Stop the engine and disconnect the spark plug lead before attempting to carry out maintenance procedures on the mower.

## ENGINE

1. Engine Cowl
2. Carburettor
3. Spark Plug / Lead
4. Muffler Guard
5. Muffler
6. Oil filler Cap/ Dipstick
7. Start Grip
8. Fuel Cap
9. Finger Guard
10. Air Cleaner

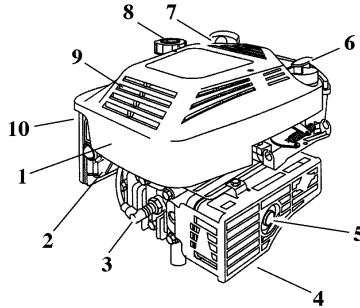

## THROTTLE CABLE ADJUSTMENT

Remove two screws securing the engine cowl and remove the cowl to expose the throttle mechanism on the front of the engine. Loosen the outer cable clamp screw (1) and move the governor control lever (2) to the left as far as possible. Insert a large, flat blade screw driver (3) into the slot in the engine control bracket (4) at the angle shown. Push the governor control lever to the right until it just touches the screw driver blade. Move the throttle control lever to the 'fast' position (not the 'choke' position) and re-tighten the outer cable clamp screw. Replace the engine cowl.

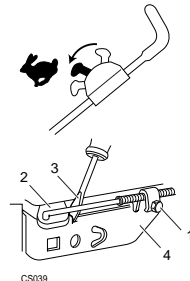

CS039

### CARBURETTOR ADJUSTMENTS

Carburettor adjustments should only be made by an authorised Briggs & Stratton dealer. Under no circumstances should the engine be adjusted to run at a speed in excess of 3,000 r.p.m.

### OIL SERVICE

Refer to the Maintenance Schedule at the end of this section and ensure that the recommendations are followed. More frequent service is required when operating in adverse conditions.

- Check the oil level every 5 hours or daily and ensure that the correct oil level is maintained. Refer to-'Before Starting the Engine Oil Recommendations' for oil checking procedure and filling instructions.
- Drain the engine oil after the first 5 hours of operation and thereafter at the end of every grass cutting season.
- Change the oil while the engine is warm. Refill with fresh clean oil of the recommended SAE viscosity grade. Refer to -'Before Starting the Engine - : Oil Recommendations'.



**WARNING - PREVENT ACCIDENTS: Drain fuel by running the engine until the fuel tank is empty and the engine stops before attempting to tip the mower for oil draining purposes.**

- Remove the spark plug lead and allow the engine to cool. Tip the mower over on to its left hand side thus ensuring that the air cleaner is kept uppermost to prevent engine damage. Remove the oil filler dipstick and drain the oil into a suitable container.

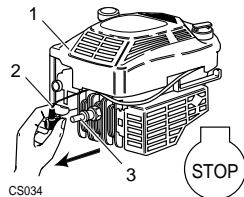

CS034

1. Engine
2. Spark Plug Lead
3. Spark plug

### DUAL ELEMENT AIR CLEANER SERVICE

Refer to the Maintenance Schedule at the end of this section and ensure that the recommendations are followed. More frequent service is required when operating in adverse conditions.

- Gain access to the pre-cleaner (4) and cartridge (3) by loosening screw (1) and tilting cover (2).

- To service the pre-cleaner, carefully remove and wash in a solution of liquid detergent and water. Allow to air dry thoroughly before replacing.

- Clean the cartridge by tapping gently on a flat surface. If very dirty, replace or wash in a solution of non-foaming detergent and warm water. Rinse thoroughly with running water from the mesh side until the water is clear. Allow the cartridge to stand and air dry thoroughly before replacing. Do not use petroleum solvents during cleaning as this will cause the cartridge to deteriorate. Do not use pressurised air as this may damage the cartridge. Do not oil the cartridge.

- After servicing, install the pre-cleaner and cartridge in the cover. Insert the tabs on the bottom of the cover into the slots in the bottom of the base (5). Tilt the cover upwards and securely tighten the screw to the base.

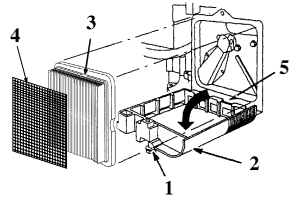

1. Screw
2. Tilting Cover
3. Cartridge
4. Pre-cleaner
5. Base Cover

### SPARK PLUG SERVICE

Use only Briggs & Stratton spark tester (1) to check for a spark as shown in the diagram.

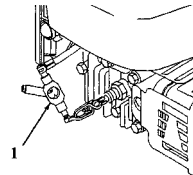

Replace the spark plug every 100 hours or every season, whichever occurs first. A spark plug wrench is available from any authorised Briggs & Stratton service dealer.

The spark plug gap (2) should be checked with a feeler gauge and set at 0.76mm (0.030").

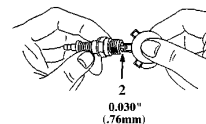

**KEEPING THE ENGINE CLEAN**

**!** **WARNING - PREVENT ACCIDENTS :** Accumulation of debris around the muffler could cause a fire. Inspect and clean the engine after every use.

Remove all grass and debris from the engine including the muffler / muffler guard, the air ways in the top cowl and the surrounding deck areas on a daily basis after use.

**IMPORTANT - PREVENT ENGINE DAMAGE:** Never spray the engine with water during cleaning. Water can contaminate the fuel. Always clean with a brush or compressed air.

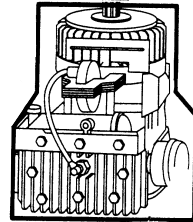

**NOTE:** Grass and debris may clog the engine's air cooling system especially after prolonged operation while cutting tall, dry grass. The internal cooling fins and surfaces may require cleaning to prevent overheating and engine damage. This may be achieved by cleaning all areas shown within the black boundary line. We would recommend that this service be carried out by an authorised Briggs & Stratton dealer.

**GRASSBAG**

Remove grass debris from the grassbag immediately after use and check its condition for signs of damage.

**!** **WARNING - PREVENT ACCIDENTS:** Replace a damaged grassbag immediately.

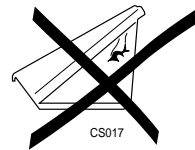
**DECK HOUSING**

Remove grass debris from the top and underside of the deck housing immediately after use.

**IMPORTANT - PREVENT DAMAGE:** Fertilisers and top dressings are particularly corrosive. Thoroughly clean the mower deck immediately after use on treated grass and store well away from corrosive materials.

**SECURING NUTS AND BOLTS**

Regularly check that all securing nuts and bolts are tight. Replace missing or damaged items immediately.

**LUBRICATION**

Lubricate the wheels, pivot points and linkages with engine oil every 25 operating hours.

Apply a good quality medium grease to the inner control cables at the point of entry and exit from their outer casings.

**CLUTCH CABLE ADJUSTMENT**

Check the clutch cable operation every 25 operating hours and adjust if necessary. The clutch cable is adjusted correctly when the belt drive just engages with the clutch lever positioned 32-38mm (1.1/4" - 1.1/2") from the handlebar.

Unscrew the lock nuts (1) and screw the adjuster (2) in or out as necessary. Tighten the locknuts (1) when correctly adjusted.

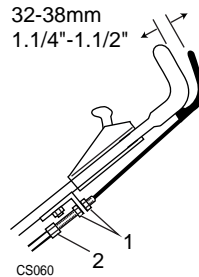

**IMPORTANT - PREVENT DAMAGE: ALWAYS operate the mower with the clutch cable correctly adjusted. ALWAYS replace damaged cables.**

## CUTTERBAR



**WARNING - PREVENT ACCIDENTS:** Never work on the cutterbar unless the spark plug lead has been removed. The cutterbar has sharp edges. **ALWAYS** wear strong gloves to protect your hands when working on the cutterbar. **DO NOT** rotate tools towards the cutting edges to avoid the risk of injury should the tool slip. **ALWAYS** use genuine Hayter replacement parts.

The condition of the cutterbar and its mounting arrangement should be checked regularly for signs of wear or damage. Ensure that the cutterbar is not bent or cracked.

A damaged cutterbar that is out of balance will vibrate excessively and may break. **DO NOT** use an unbalanced cutterbar.

Regularly check that the bolt securing the cutterbar is tightened to the specified torque of 54Nm (40 lbs ft).

Replace the cutterbar every 2 years or sooner if excessively worn or damaged.

**How to remove the cutterbar:** Drain the fuel by running the engine until the fuel tank is empty and the engine stops. **Remove the spark plug lead** and allow the engine to cool. Turn the mower on its left hand side and ensure that the air cleaner side of the engine is uppermost.

**CAUTION - PREVENT INJURY:** It is wise to seek assistance when turning the mower onto its side.

Firmly grip the end of the cutterbar with the gloved hand and remove the 2 fixing screws (1) securing the cutterbar (2).

**How to assemble the cutterbar:** Assemble the cutterbar (2) with the turned up edges facing towards the engine. Secure the cutterbar using two new fixing screws and tighten to 40Nm torque.

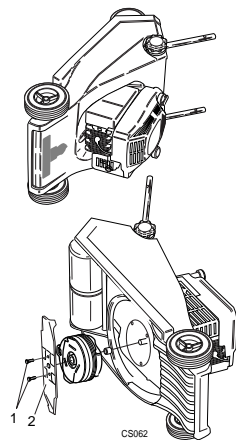

**WARNING - PREVENT ACCIDENTS:** Never reuse the fixing screws. Always use new cutterbar fixing screws when refitting or replacing the cutterbar.



**CUTTERBAR**

Continued.

**How to sharpen and balance the cutterbar:** A slightly worn cutterbar may be re-sharpened. Both cutting edges must be sharpened equally to ensure balance. Sharpen the cutterbar every 25 mowing hours or more frequently if conditions require. Remove the cutterbar from the mower and clean using a brush and water. Inspect the cutterbar for signs of damage.

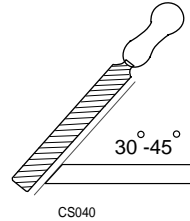

**WARNING - PREVENT ACCIDENTS : DO NOT use a damaged or excessively worn cutterbar.**

Sharpen both cutting edges with a flat file to restore the original cutting edge.

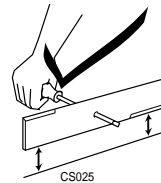

Ensure that the cutterbar is balanced. Use a screw driver with a round shaft to support the cutterbar through its centre hole. Hold the cutterbar horizontal and then release. A balanced cutterbar will remain horizontal. If the cutterbar is not balanced the heavy end will rotate downwards. Sharpen the heavy end until the cutterbar is correctly balanced.

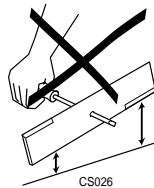

**MAINTENANCE SCHEDULE**

Follow the hourly or calendar intervals, whichever occurs first. More frequent service will be required if working for prolonged periods under dusty, dry conditions, or when airborne debris is present or after extensive operation cutting tall, dry grass.

**AFTER FIRST 5 HOURS**

- *Change engine oil*

**EVERY 5 HOURS OR DAILY**

- *Check oil level*
- *Remove grass debris from around engine, muffler/muffler guard and air ways in the top cowl.*
- *Remove grass debris from top and underside of deck housing.*
- *Remove grass debris from the grassbag and check for signs of damage.*
- *Check condition of guards and safety devices.*
- *Check condition of cutterbar.*

**EVERY 25 HOURS OR EVERY SEASON**

- *Change engine oil if continuously operating under heavy load or high ambient temperature.*
- *Service the dual element air cleaner - pre cleaner.*
- *Lubricate wheels, pivot points and linkages.*
- *Grease inner control cables at point of entry and exit from their outer casings.*
- *Check clutch cable adjustment.*
- *Sharpen cutterbar.*

**MAINTENANCE SCHEDULE Continued.****EVERY 50 HOURS OR EVERY SEASON**

- *Change engine oil.*

**EVERY 100 HOURS OR EVERY SEASON**

- *Clean engine cooling system. Clean more often under dusty conditions or when airborne debris is present or after prolonged operation whilst cutting tall, dry grass.*
- *Service the dual element air cleaner cartridge.*
- *Replace spark plug.*

**PREPARING THE MOWER FOR STORAGE**

**Handlebar storage:** To lower the handlebar unscrew the 2 small securing knobs sufficiently to allow it to be pivoted forwards to rest against the mower. Take care to ensure that the control cables do not become snagged at the pivot point and depress the engine stop lever to prevent it being damaged through contact with the engine spark plug.

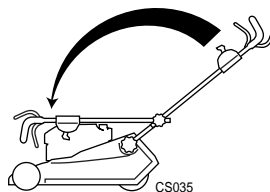

**Storage for periods in excess of 30 days:** Engines stored in excess of 30 days need to be protected with Briggs & Stratton fuel additive or drained of fuel to prevent gum from forming in the fuel system or on essential carburettor parts. To ensure your mower is maintained in good working order it is important that the following procedure is adopted. Refer to the Maintenance section as necessary.

Drain fuel from the engine by operating the engine until it stops.

Disconnect the spark plug lead.

Change the engine oil.

Remove the engine spark plug and pour 15ml of engine oil into the engine cylinder and replace the spark plug. Do not exceed the stated volume of oil as engine damage may occur on re-starting. **Do not replace the spark plug lead.** Slowly pull the engine start - grip once to crank the engine. This will distribute the oil and help prevent engine corrosion.

Clean grass and debris from the engine cylinder, cylinder head cooling fins, under top cowl, and around and behind muffler/muffler guard.

Clean all other areas of the mower and ensure that the grassbag is clean.

Lubricate the mower.

Treat metal parts with a water repellent anti-corrosion product.

Lower the handlebar, if desired.

Rest the mower deck on wooden blocks to remove the mower from its wheels / roller.

Cover the mower with a protective sheet and store it in a dry, ventilated area.

**IMPORTANT: Fertilisers and top dressing are particularly corrosive. Thoroughly clean the mower immediately after use on treated grass and store well away from corrosive materials.**

**FAULT FINDING**

<b>PROBLEM</b>	<b>POSSIBLE FAULT</b>	<b>REMEDY</b>
Engine will not turn over	Engine stop lever released Incorrect oil level	Operate engine stop lever Check oil level
Engine smokes	Excess oil level Air cleaner cartridge oil soaked or plugged	Check oil level Service air cleaner
Engine runs then stops	Fuel starvation Fuel cap vent blocked	Fill fuel tank Clean fuel cap vent

**FAULT FINDING**
**Continued.**

<b>PROBLEM</b>	<b>POSSIBLE FAULT</b>	<b>REMEDY</b>
Engine will not start	Engine under load Fuel starvation Engine cold Incorrect/contaminated fuel Spark plug lead disconnected Throttle setting incorrect Engine brake not released Faulty spark plug	Raise height of cut Fill fuel tank Set throttle to 'choke' position Drain fuel tank and fill with correct fuel Connect spark plug lead Set throttle to 'fast' position Operate engine brake lever Clean and adjust gap or replace
Engine runs rough	Spark plug lead becoming disconnected in use Faulty spark plug Air cleaner blocked Incorrect/contaminated fuel	Connect spark plug lead Clean and adjust gap or replace Service air cleaner Drain fuel tank and fill with correct fuel
Engine vibrates excessively	Mounting bolts loose Cutterbar screws loose Cutterbar out of balance Bent crankshaft	Tighten bolts Tighten screws Balance cutterbar Consult your dealer
Cutterbar drive will not engage / disengage	Faulty blade brake clutch	Consult your dealer

**FAULT FINDING**

Continued.

<b>PROBLEM</b>	<b>POSSIBLE FAULT</b>	<b>REMEDY</b>
Uneven cut	Undulating ground conditions	Change direction of travel
	Cutterbar worn	Sharpen the cutterbar
	Cutterbar out of balance	Balance the cutterbar
	Wheels / roller damaged	Inspect and replace as necessary
Discharge chute blocks	Grass is wet	Mow dry grass
	Cut height too low	Increase cut height
	Grassbag full	Empty grassbag
	Slow engine speed	Increase engine speed
	Airflow through the grassbag is restricted	Clean the grassbag
Mower is hard to push	Cut height too low	Increase cut height
	Wheels / roller damaged	Inspect and lubricate or replace as necessary
Mower will not self propel	Clutch out of adjustment	Adjust clutch cable
	Drive belt damaged	Replace drive belt
Poor grass collection	Airflow through the grassbag is restricted	Clean the grassbag
	Discharge chute blocked	Remove blockage
	Slow engine speed	Increase engine speed
	Wet grass	Mow dry grass
	Grassbag full	Empty grassbag

## PARTS LIST

ITEM NO.	DESCRIPTION	PART NO.	QTY
1	Mainframe - Casting	480010V	1
2	Plate - Location RH	480083V	1
3	Clamp - Boss Inner	480084W	2
4	Clamp - Boss Outer	480085W	2
5	Handwheel - Assy	480054	2
6	Spacer - BBC	485006	1
7	Throttle Control & OPC Cable	485026	1
8	Engine - B/S Diamond XTL50 APTO	485110	1
9	Decal - Engine	485111	1
10	Knob - Handlebar	480088	2
11	Handlebar - Lower	480089W	2
12	Bolt - Handlebar	226024	2
13	Nut - Nylon Insert	09544	3
14	Washer - Plain	09472	1
15	Guide Rope	305093	1
16	Bush Lever	226034	3
17	Decal - Operation	343019	1
18	Blade Stop Lever	319006W	1
19	Plastic Ferrule	305115	1
20	Handlebar	485008W	1
21	Lever - Clutch	219090	1
22	Plastic Nut Cap M6	343025	2
23	Cable Guide	480123	1
24	Bracket - Cable Clutch	306108	1
25	Screw - Deltite Posi Pan	09600	2
26	Cable - Clutch	480094	1
27	Grassbag Assy (includes items 28, 36,104 & 105)	480109	1
28	Frame - Grassbag	480058W	1
29	Deflector - Rear	480140	1
30	Pin - Roll	03997	1
31	Spring - Deflector RH	480131	1
32	Rod - Deflector	480062	1
33	Screw - Hex. Hd. Taptite	09758	2
34	Bolt - Coach	09549	2
35	Knob - HOC	480134	1
36	Base/Fabric - Grassbag Assy	480107	1
37	Spring - Deflector LH	480130	1
38	Plate - Location LH	480082V	1
39	Plate - Handlebar Retainer	480055	2
40	Cover - APTO	480014	1
41	Bearing - APTO	480050	1
42	Screw - Washer Hd Taptite	09575	3



## PARTS LIST

ITEM NO.	DESCRIPTION	PART NO.	QTY
43	Bush	340154	2
44	Screw - Taptite	09591	3
45	Foam Strip	480119	1
46	Lever HOC	480128	1
47	HOC Moulding	480126	1
48	Throwplate - Main Body	480011	1
49	Screw - Taptite	09545	4
50	Bearing - Roller Housing	219102	2
51	Roller - Rear W/A	480151W	2
52	Spring Tension - Rear Axle	480133	2
53	Washer	09262	3
54	Screw - Taptite	09365	22
55	Bush - Oilite Roller	340129	2
56	Roller Freewheel - Rocket Band	340150	2
57	Spacer - Nylon	340149	2
58	Shroud - Freewheel	340168	1
59	Locknut	340163	1
60	Shaft - Roller	480032	1
61	Sprocket - 22 Teeth	480039	1
62	Frame - Rear Roller W/A (inc. item 114)	480159W	1
63	Key - woodruff	5321	1
64	Circlip	1428	1
65	Washer	480097	4
66	Cover - Transmission	480043	1
67	Chain	480068	1
68	Rod - Connecting	480045	1
69	Plate - Securing	219037	2
70	Filler - Throwplate	480017W	1
71	Pulley - Sprocket Fixedspeed	480095	1
72	Belt - V APTO	480063	1
73	Washer	02575	1
74	Circlip	03096	1
75	Pulley - Jockey	219156	1
76	Washer - Starlock	0201086	2
77	Bracket - Idler Assy	480115	1
78	Belt Guide	480116	1
79	Pulley - Drive APTO	480038	1
80	Spring - Torsion Idler	480066	1
81	Bush	4452	1
82	Washer - Plain	09280	1

## PARTS LIST

ITEM NO.	DESCRIPTION	PART NO.	QTY
83	Nut M4 - Nylon Insert	09657	1
84	M10 x 25 Tuf-Lok Screw	09747	2
85	Blade Brake Clutch	485007	1
86	Cutterbar - BBC	485005	1
87	Cover - Throwplate Drive	480012	1
88	Support Plate Assy	319008W	1
89	Spacer	321034	3
90	Cap - Hub	219143	2
91	Nut - UNF Nyloc	4486	2
92	Wheel	5218	2
93	Axle - Front W/A	219031	1
94	Moulding - Front axle Bearing	219036	2
95	Fin - Front Insert	480013	1
96	Decal - Hayter & Royal Warrant	219186	1
97	Nut - M8 Shouldered	480086	2
98	Guide - Rope	305127	1
99	Plug - Tube	300160	2
100	Tie - Cable	3966	6
101	Setscrew	09704	1
102	Control - BBC Assy	485028	1
103	Screw Pan Hd.	09384	2
104	Grassbag Filler	480052	1
105	Grassbag Top	480107	1
106	Nipple Split	510118	1
107	Compensating Spring	319018	1
108	Spring	343011	1
109	Centre Bolt BBC	343029	1
110	Screw Soc. Shld	ZIS8L030S	1
111	Screws	09634	1
112	Clip - Cable	287034	1
113	Torsion Spring HOC	480132	1
114	Bracket HOC	480157W	1
115	Rivets	-	2
116	Ratchet	480156	1
117	Cover Plate	480018	1
118	Screw	09687	1

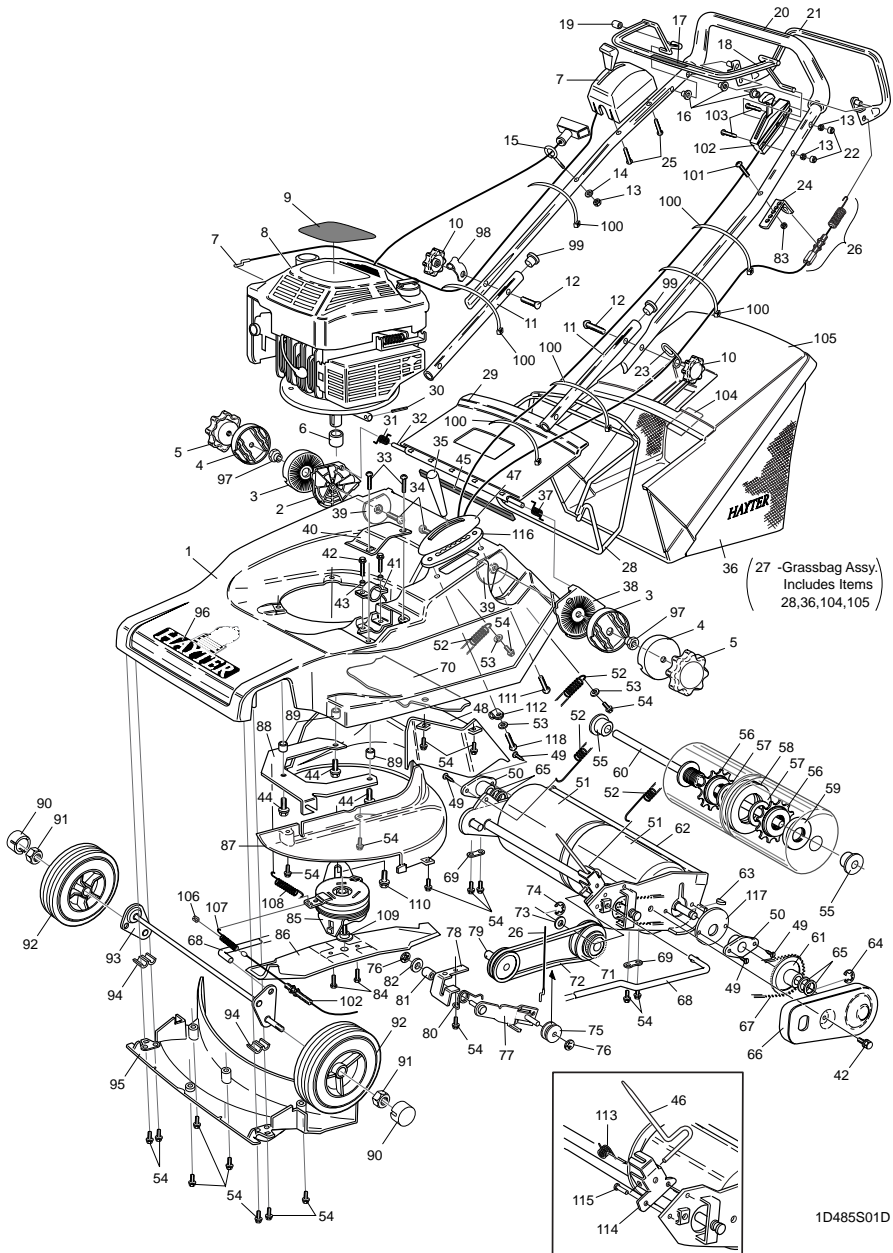

1D485S01D

These parts are available through an authorised Briggs & Stratton dealer.

**FUEL ADDITIVE**

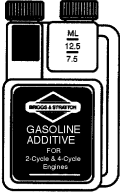

**P/N 5041**  
**999005E**



**992030**

**AIR CLEANER CARTRIDGE**

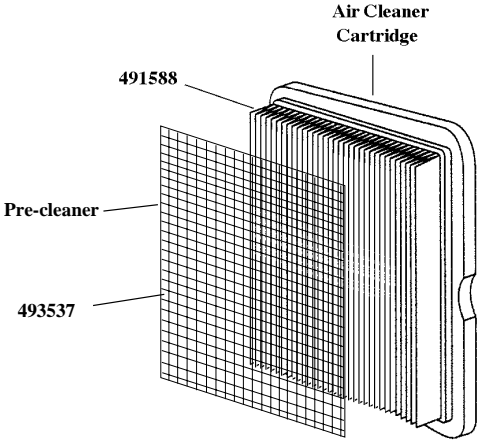

Air Cleaner Cartridge

491588

Pre-cleaner

49357

**SPARK PLUG**

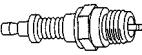

**802592E**

**SPARK PLUG WRENCH**

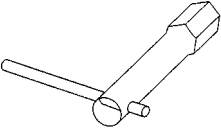

**89838**

**SPARK PLUG TESTER**

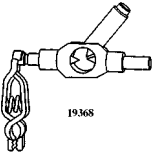

**19368**

### About Your Engine Warranty

Briggs & Stratton welcomes warranty repair and apologizes to you for being inconvenienced. Any Authorized Service Dealer may perform warranty repairs. Most warranty repairs are handled routinely, but sometimes requests for warranty service may not be appropriate. For example, warranty would not apply if engine damage occurred because of misuse, lack of routine maintenance, shipping, handling, warehousing or improper installation. Similarly, warranty is void if the serial number of the engine has been removed or the engine has been altered or modified. If a customer differs with the decision of the Service Dealer, an investigation will be made to determine whether the warranty applies. Ask the Service Dealer to submit all supporting facts to his Distributor or the Factory for review. If the Distributor or the Factory decides that the claim is justified, the customer will be fully reimbursed for those items that are defective. To avoid misunderstanding which might occur between the customer and the Dealer, listed below are some of the causes of engine failure that the warranty does not cover.

#### Improper maintenance:

The life of an engine depends upon the conditions under which it operates, and the care it receives. Some applications, such as tillers, pumps and rotary mowers, are very often used in dusty or dirty conditions, which can cause what appears to be premature wear. Such wear, when caused by dirt, dust, spark plug cleaning grit, or other abrasive material that has entered the engine because of improper maintenance, is not covered by warranty.

This warranty covers engine related defective material and/or workmanship only, and not replacement or refund of the equipment to which the engine may be mounted. Nor does the warranty extend to repairs required because of:

1. PROBLEMS CAUSED BY PARTS THAT ARE NOT ORIGINAL BRIGGS & STRATTON PARTS.
2. Equipment controls or installations that prevent starting, cause unsatisfactory engine performance, or shorten engine life. (Contact equipment manufacturer.)
3. Leaking carburetors, clogged fuel pipes, sticking valves, or other damage, caused by using contaminated or stale fuel. (Use clean, fresh, lead-free gasoline and Briggs & Stratton gasoline stabilizer, Part No. 5041.)
4. Parts which are scored or broken because an engine was operated with insufficient or contaminated lubricating oil, or an incorrect grade of lubricating oil (check oil level daily or after every 8 hours of operation. Refill when necessary and change at recommended intervals.) Read "Owner's Manual".
5. Repair or adjustment of associated parts or assemblies such as clutches, transmissions, remote controls, etc., which are not manufactured by Briggs & Stratton.
6. Damage or wear to parts caused by dirt, which entered the engine because of improper air cleaner maintenance, re-assembly, or use of a non-original air cleaner element or cartridge. (At recommended intervals, clean and re-oil the Oil-

Foam<sup>®</sup> element or the foam pre-cleaner, and replace the cartridge.) Read "Owner's Manual."

7. Parts damaged by over-speeding, or overheating caused by grass, debris, or dirt, which plugs or clogs the cooling fins, or flywheel area, or damage caused by operating the engine in a confined area without sufficient ventilation. (Clean fins on the cylinder, cylinder head and flywheel at recommended intervals.) Read "Owner's Manual."
8. Engine or equipment parts broken by excessive vibration caused by a loose engine mounting, loose cutter blades, unbalanced blades or loose or unbalanced impellers, improper attachment of equipment to engine crankshaft, over-speeding or other abuse in operation.
9. A bent or broken crankshaft, caused by striking a solid object with the cutter blade of a rotary lawn mower, or excessive v-belt tightness.
10. Routine tune-up or adjustment of the engine.
11. Engine or engine component failure, i.e., combustion chamber, valves, valve seals, valve guides, or burned starter motor windings, caused by the use of alternate fuels such as, liquefied petroleum, natural gas, altered gasolines, etc.

Warranty is available only through service dealers which have been authorized by Briggs & Stratton Corporation, your nearest Authorized Service Dealer is listed in the "Yellow Pages"™ or your telephone directory under "Engines, Gasoline"™ or "Gasoline Engines," "Lawn Mowers," or similar category.

### Briggs & Stratton Engine Owner Warranty Policy

Effective February 1, 1984, replaces all undated Warranties and all Warranties dated before February 1, 1984

#### LIMITED WARRANTY

"Briggs & Stratton Corporation will repair or replace, free of charge, any part, or parts of the engine that are defective in material or workmanship or both. Transportation charges on parts submitted for repair or replacement under this Warranty must be borne by purchaser. This warranty is effective for the time periods and subject to the conditions provided for in this policy. For warranty service contact your nearest Authorized Service Dealer as listed in the "Yellow Pages"™ under "Engines, Gasoline," "Gasoline Engines," "Lawn Mowers" or similar category. THERE IS NO OTHER EXPRESS WARRANTY. IMPLIED WARRANTIES, INCLUDING THOSE OF MERCHANTABILITY AND FITNESS FOR A PARTICULAR PURPOSE ARE LIMITED TO ONE YEAR FROM PURCHASE, OR TO THE EXTENT PERMITTED BY LAW ANY AND ALL IMPLIED WARRANTIES ARE EXCLUDED. LIABILITY FOR CONSEQUENTIAL DAMAGES UNDER ANY AND ALL WARRANTIES ARE EXCLUDED TO THE EXTENT EXCLUSION IS PERMITTED BY LAW. Some states do not allow limitations on how long an implied warranty lasts, and some states do not allow the exclusion or limitation of incidental or consequential damages, so the above limitation and exclusion may not apply to you. This warranty gives you specific legal rights and you may also have other rights which vary from state to state."

Briggs & Stratton Corporation

*F. P. Stratton, Jr.*  
F. P. Stratton, Jr.  
Chairman and Chief Executive Officer

#### WARRANTY PERIOD

ENGINES	WITHIN U.S.A. AND CANADA		OUTSIDE U.S.A. AND CANADA	
	CONSUMER USE*	COMMERCIAL USE*	CONSUMER USE*	COMMERCIAL USE*
All Vanguard™ engines.			2 year - engine / Lifetime™ - Magneton® ignition	
All Diamond Plus®, Europa™, Industrial Plus™ and all IC®.	2 year	1 year	2 year	1 year
Quantum® and Diamond Power®.	2 year	90 days	2 year †	90 days
All standard 2 through 18 HP engines installed on lawn mowers, riders, edgers, chippers, shredders, tillers, and all Sno/Gard engines.	2 year	90 days	1 year	90 days
All other standard 2 through 18 HP engines.	1 year	90 days	1 year	90 days

\* For purposes of this warranty policy, "consumer use" means personal residential household use by the original retail consumer. "Commercial use" means all other uses, including use for commercial, income producing or rental purposes. Once an engine has experienced commercial use, it shall thereafter be considered as a commercial use engine for purposes of this warranty. Engines used in competitive racing or on commercial or rental tracks are not warranted.

\*\* Lifetime limited warranty of the Magneton® ignition covers parts and labor for the first five (5) years from the date of purchase; thereafter only parts. "Lifetime" means lifetime of the engine in the hands of the original purchaser.

† One (1) year in Australia, New Zealand, Middle East and Africa.

**NO WARRANTY REGISTRATION CARD IS NECESSARY TO OBTAIN WARRANTY ON BRIGGS & STRATTON ENGINES. YOU MUST SAVE THE PURCHASE RECEIPT. A PROOF OF PURCHASE DATE WILL BE REQUIRED TO OBTAIN WARRANTY.**

Briggs & Stratton Engines Are Made Under One Or More Of The Following Patents: Design D-247,177 (Other Patents Pending)										
5.220.795	5.285.700	5.187.422	5.105.301	5.040.503	4.992.377	4.895.119	4.520.288	4.355.253	4.168.288	DES. 308.872
5.217.383	5.243.878	5.191.884	5.066.890	5.016.588	4.977.879	4.819.593	4.453.570	4.270.500	DES. 309.458	DES. 308.871
5.269.713	5.197.425	5.150.674	5.040.644	4.998.956	4.971.219	4.694.792	4.430.984	4.233.534	DES. 309.457	



Machine Serial No: .....

Engine Serial No: .....